

52 290

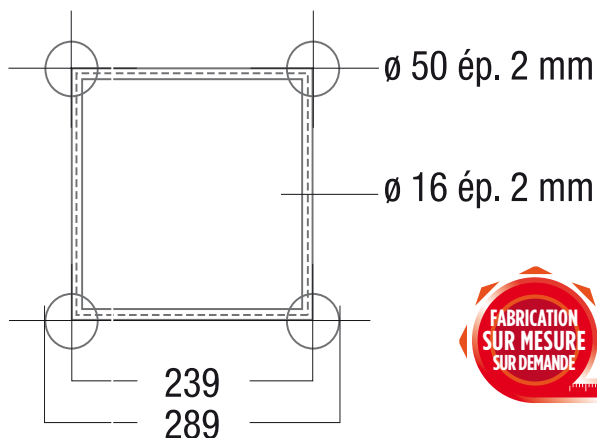

CHARGES MAXIMALES (1/100) *							
Portée (m)	Flèche (mm)	Q	P1	P2 P2	P3 P3 P3	P4 P4 P4 P4	SW (kg)
		(kg/ml)	(kg)	(kg/pt2)	(kg/pt3)	(kg/pt4)	
1	10	1545	1545	772	515	386	5
2	20	770	1540	770	513	385	10
3	30	512	1260	767	512	384	15
4	40	382	936	707	471	382	20
5	50	301	740	561	374	312	25
6	60	207	607	463	309	258	30
7	70	151	511	392	261	219	35
8	80	115	438	339	226	189	40
9	90	89	380	296	197	166	45
10	100	71	332	262	175	147	50
11	110	58	293	233	155	131	55
12	120	48	259	209	139	118	60
13	130	40	229	188	125	106	65
14	140	34	203	170	113	96	70
15	150	29	180	154	102	87	75
16	160	25	159	139	93	80	80
17	170	21	140	121	84	71	85
18	180	17	122	101	75	60	90
19	190	14	106	83	62	50	95
20	200	11	91	68	51	42	100

CHARGES PRÉCONISÉES (1/300) *							
Portée (m)	Flèche (mm)	Q	P1	P2 P2	P3 P3 P3	P4 P4 P4 P4	SW (kg)
		(kg/ml)	(kg)	(kg/pt2)	(kg/pt3)	(kg/pt4)	
1	3	1545	1545	772	515	386	5
2	7	770	1540	770	513	385	10
3	10	512	1260	767	512	384	15
4	13	382	936	707	471	382	20
5	17	301	740	561	374	312	25
6	20	194	607	422	304	239	30
7	23	120	511	304	219	172	35
8	27	79	379	226	163	129	40
9	30	54	286	172	124	98	45
10	33	38	218	132	96	76	50
11	37	27	167	103	75	60	55
12	40	20	126	79	58	47	60
13	43	15	94	61	45	36	65
14	47	11	67	45	34	28	70
15	50	8	44	32	25	21	75
16	53	5	25	22	17	15	80
17	57	4	8	12	11	9	85
18	60	2	N.A	4	5	5	90
19	63	1	N.A	N.A	N.A	1	95
20	67	0	N.A	N.A	N.A	N.A	100

Sous réserve que l'utilisateur ait vérifié au préalable la stabilité au non-basculement de la poutre

*Bien comprendre les taux de flèche, se reporter page 4