

## SC 390

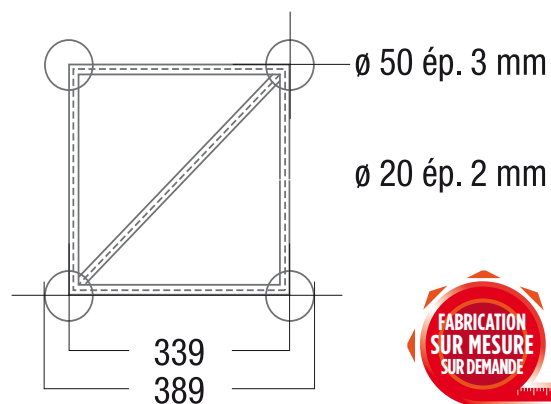

CHARGES MAXIMALES (1/100) *							
Portée (m)	Flèche (mm)	Q	P1	P2 P2	P3 P3 P3	P4 P4 P4 P4	SW (kg)
		Q (kg/ml)	P1 (kg)	P2 (kg/pt2)	P3 (kg/pt3)	P4 (kg/pt4)	
1	10	2441	2441	1221	814	610	8
2	20	1217	2433	1217	811	608	15
3	30	809	2237	1213	809	606	23
4	40	604	1664	1209	806	604	31
5	50	482	1318	998	665	555	39
6	60	369	1084	824	550	459	46
7	70	269	915	699	466	390	54
8	80	204	786	605	403	338	62
9	90	160	684	530	354	297	69
10	100	128	601	470	313	263	77
11	110	104	532	420	280	236	85
12	120	86	473	378	252	212	92
13	130	73	421	341	227	192	100
14	140	61	376	309	206	175	108
15	150	53	337	281	188	159	116
16	160	45	301	256	171	146	123
17	170	39	268	234	156	133	131
18	180	34	238	213	142	122	139
19	190	30	211	194	130	112	146
20	200	26	185	177	118	103	154

CHARGES PRÉCONISÉES (1/300) *							
Portée (m)	Flèche (mm)	Q	P1	P2 P2	P3 P3 P3	P4 P4 P4 P4	SW (kg)
		Q (kg/ml)	P1 (kg)	P2 (kg/pt2)	P3 (kg/pt3)	P4 (kg/pt4)	
1	3	2441	2441	1221	814	610	8
2	7	1217	2433	1217	811	608	15
3	10	809	2237	1213	809	606	23
4	13	604	1664	1209	806	604	31
5	17	482	1318	998	665	555	39
6	20	369	1084	824	550	459	46
7	23	269	915	699	466	390	54
8	27	204	786	605	403	338	62
9	30	160	684	530	354	297	69
10	33	118	601	422	305	240	77
11	37	87	532	338	245	193	85
12	40	65	452	274	199	157	92
13	43	49	364	222	162	128	100
14	47	38	292	181	133	105	108
15	50	29	233	147	108	86	116
16	53	23	183	118	88	71	123
17	57	18	141	94	71	57	131
18	60	14	104	73	56	45	139
19	63	11	71	54	43	35	146
20	67	8	42	38	31	26	154

Sous réserve que l'utilisateur ait vérifié au préalable la stabilité au non-basculement de la poutre

\*Bien comprendre les taux de flèche, se reporter page 4